

# Masonry drills

## Steen- & betonboren

## Forets à pierre & béton

### DRILL ANATOMY / BOOR ANATOMIE / ANATOMIE DU FORET

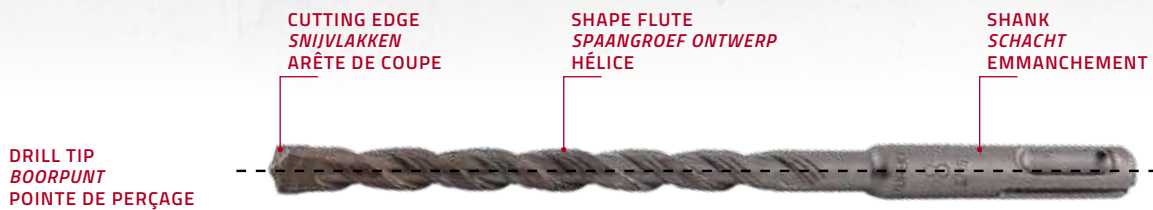

### DRILLING HEAD / BOORKOP / TÊTE DE PERÇAGE



The shape of the drilling head influences the lifetime but also its effectiveness on the materials. A drill with more cutting edges will perform better in hard materials and reinforced concrete.

*De vorm van de boorkop heeft invloed op de levensduur, maar ook de efficiëntie op de materialen. Een boor met meer snijranden zal beter presteren in harde materialen en gewapend beton.*

La forme de la tête de perçage influence la durée de vie mais également son efficacité sur les matériaux. Un foret possédant un plus grand nombre de taillants sera plus performant dans les matériaux durs et le béton armé.

### DRILL TIP / BOORPUNT / POINTE DE PERÇAGE



The tip allows precision drilling throughout the operation. The penetration of the drill makes the material friable for the purpose of being evacuated through the drilling hole.

*De punt maakt precisie boren mogelijk tijdens de handeling. Door de penetratie van de boor wordt het materiaal gebroken met het doel om door het boorgat te worden geëvacueerd.*

La pointe permet un forage de précision pendant toute la manoeuvre. La pénétration du foret rend le matériau friable dans le but d'être évacué par le trou de perçage.

### SHAPE FLUTE / SPAANGROEF ONTWERP / HÉLICE



The shape of the helices are adapted to the diameter of the drill in order to improve the extraction of the dust.

*De vorm van de spaangroeven zijn aangepast aan de diameter van de boor om de verwijdering van het stof te verbeteren.*

La forme des hélices est adaptée au diamètre du foret dans le but d'améliorer l'extraction de la poussière.

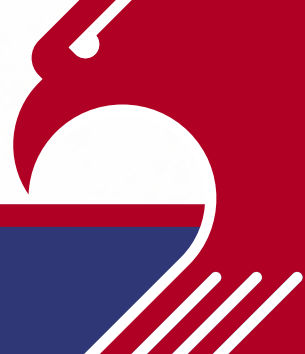

## SHANK TYPE / SCHACHT TYPE / TYPE D'EMMANCHEMENT



Cylindrical shank  
Cilindrische schacht  
Queue à emmanchement cylindrique



3-flat shank  
Schacht met 3 vlakke zijden  
Queue à emmanchement à 3-pans



SDS-plus shank for the impact drill machines less than 5 kg  
SDS-plus schacht voor boorhamermachines van minder dan 5 kg



Emmanchement SDS-plus pour les marteaux perforateurs de moins de 5 kg



SDS-max shank for the impact drill machines more than 5 kg  
SDS-max schacht voor boorhamermachines van meer dan 5 kg



Emmanchement SDS-max pour les marteaux perforateurs de plus de 5 kg

## APPLICATIONS OVERVIEW TOEPASSINGSOVERZICHT APERÇU DES APPLICATIONS

	BRICK	HOLLOW BRICK	CELLULAR CONCRETE	CONCRETE	REINFORCED CONCRETE	GRANITE	MARBLE	STONE / ROCK	FIBER CEMENT	CERAMIC
BRICKSTONE	■ ■ ■	■ ■ ■ ■	■ ■ ■ ■	■ ■ ■ ■				■	■	
GRANITE	■ ■ ■ ■	■ ■ ■ ■	■ ■ ■ ■	■ ■ ■		■ ■	■	■ ■	■ ■	■ ■
GRANITEC	■ ■ ■ ■	■ ■ ■ ■	■ ■ ■	■ ■ ■ ■		■ ■	■ ■	■ ■		■ ■ ■ ■
MULTITEC	■ ■	■ ■	■ ■			■ ■	■ ■	■ ■	■ ■	■
2-CUTTER	■ ■	■	■	■ ■ ■ ■	■ ■	■ ■	■ ■	■ ■	■ ■	
4-CUTTER	■ ■	■	■	■ ■ ■ ■	■ ■ ■ ■	■ ■ ■ ■	■	■ ■ ■ ■	■ ■	

■ ■ ■ 1° choice / 1° keus / 1° choix

■ ■ recommended / aanbevolen / recommandé

■ suitable / geschikt / apte



## BRICKSTONE

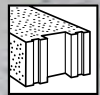
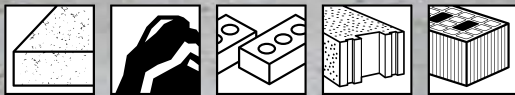

**1 CARBIDE TIPPED**  
Ensures long life and high resistance  
**CARBIDE PUNT**  
Zorgt voor een lange levensduur en een hoge weerstand  
**POINTE EN CARBURE**  
Assure une grande longévité et une grande résistance

**2 CENTERING POINT**  
Allows an excellent centering during the implementation  
**CENTREERPUNT**  
Zorgt voor een uitstekende centrering bij het starten  
**POINTE DE CENTRAGE**  
Permet un excellent centrage lors du démarrage

**3 2 CUTTING EDGES WITH 130° ANGLE**  
Ensures a neat drill input and output  
**2 SNIJRANDE MET EEN HOEK VAN 130°**  
Zorgt voor een nette booringang en -uitgang  
**2 TAILLANTS AVEC ANGLE DE 130°**  
Assure un perçage d'entrée et de sortie net



**4 DOUBLE HELIX**  
Ensures good dust extraction  
**DUBBEL SPAANGROEFONTWERP**  
Garandeert een goede stofverwijdering  
**DOUBLE HÉLICE**  
Garanti une bonne évacuation de la poussière

**5 SANDBLASTED SURFACE**  
**GEZANDSTRAALD OPPERVLAK**  
**CORPS DU FORET SABLÉ**

**6 CYLINDRICAL SHANK**  
**CILINDRISCHE SCHACHT**  
**EMMANCHEMENT LISSE**

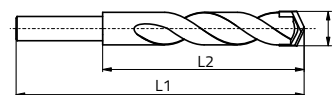

code	5420000051300	∅	mm	
			L1 mm	L2 mm
SR 25821030	5420000051300	3,0	60	30
SR 25821040	5420000051317	4,0	75	38
SR 25821050	5420000051324	5,0	85	44
SR 25821060	5420000051331	6,0	100	54
SR 25821080	5420000051348	8,0	120	67
SR 25821100	5420000051355	10,0	120	67
SR 25821120	5420000051362	12,0	150	85

code	5420000051379	<b>i</b>
<b>SET : ∅ 4 - 5 - 6 - 7 - 8 - 9 - 10 mm (MULTIPACK)</b>		
SR 25821350	5420000051379	7 pcs / 7-delig / 7 pcs

## GRANITE



**1 CARBIDE HEAD WITH A SPECIFIC GEOMETRIC SHAPE COMPRISING A CENTERING POINT AND HIGH QUALITY SOLDERING**  
Ensures long life, high resistance and excellent centering when drilling

**CARBIDE KOP MET EEN SPECIFIEKE GEOMETRISCHE VORM MET EEN CENTREERPUNT EN EEN HOOGWAARDIGE SOLDERING**  
Zorgt voor een lange levensduur, een hoge weerstand en uitstekende centrering tijdens het boren

**TÊTE EN CARBURE À FORME GÉOMÉTRIQUE SPÉCIFIQUE COMPORTANT UNE POINTE DE CENTRAGE ET SOUDURE DE HAUTE QUALITÉ**

Assure une grande longévité, une grande résistance ainsi qu'un excellent centrage lors du perçage

**2 3-POINT DRILLING HEAD**  
Allows drilling holes with greater accuracy

**3-PUNTS BOORKOP**  
Zorgt voor boorgaten met grotere nauwkeurigheid

**TÊTE DE PERÇAGE EN 3 POINTS**

Permet des trous de perçage d'une plus grande précision



**3 DOUBLE HELIX**  
Ensures good dust extraction  
**DUBBEL SPAANGROEFONTWERP**  
Garandeert een goede stofverwijdering  
**DOUBLE HÉLICE**  
Garanti une bonne évacuation de la poussière

**4 3-FLAT SHANK**  
For a perfect fit of the drill in the chuck without slipping  
**SCHACHT MET 3 VLAKKE ZIJDEN**  
Voor een perfecte pasvorm van de boor in de boorkop zonder te slippen  
**EMMANCHEMENT À 3-PANS**  
Pour un ajustement parfait du foret dans le mandrin sans risque de glisse

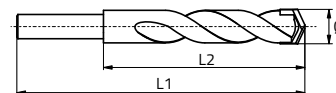
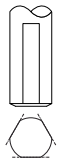

code	Ø	L1 mm	L2 mm
SR 25810100	4,0	75	45
SR 25810200	5,0	85	45
SR 25810250	6,0	100	60
SR 25810300	6,0	150	80
SR 25810320	8,0	120	75
SR 25810355	8,0	200	130
SR 25810410	10,0	120	75
SR 25810435	12,0	150	80
SR 25810460	14,0	150	80

code	SET : Ø 4 - 5 - 6 - 8 - 10 mm (MULTIPACK)
SR 25810590	5 pcs / 5-delig / 5 pcs

\* depending on the material  
afhankelijk van het materiaal  
en fonction du matériau

## GRANITEC

for very hard materials  
voor zeer harde materialen  
pour matériaux très durs

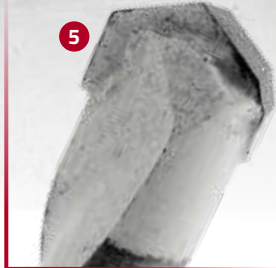
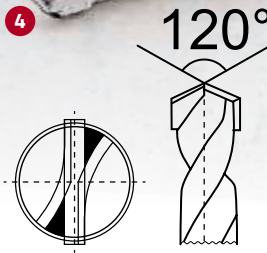
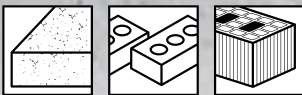

- 1 SPECIAL TUNGSTEN CARBIDE TIP WITH VERY FINE GRAIN**  
Composed of a large portion of homogeneously structured tungsten carbide guaranteeing a very high resistance to very hard materials as well as a long service life  
**SPECIALE WOLFRAMCARBIDE PUNT MET ZEER FIJNE KORREL**  
Bevat een groot deel homogeen gestructureerde wolframcarbide waardoor een zeer hoge weerstand tegen zeer harde materialen wordt gewaarborgd, alsook een lange levensduur  
**POINTE SPÉCIALE EN CARBURE DE TUNGSTÈNE AVEC GRAIN TRÈS FIN**  
Composé d'une grande portion de carbure de tungstène structuré de manière homogène garantissant une très grande résistance aux matériaux très durs ainsi qu'une longue durée de vie

- 2 ASYMMETRICAL SPIRAL DESIGN WITH STRAIGHT FLUTE ENTRY**  
For a perfect extraction of drilling residues  
**ASYMMETRISCH SPIRAALONTWERP MET RECHTE SPAANGROEFINGANG**  
Voor een perfecte verwijdering van boorresten  
**CONCEPTION SPIRALÉE ASYMÉTRIQUE AVEC ENTRÉE DE GOUJURE DROITE**  
Pour une extraction parfaite des résidus de forage

- 3 POLISHED SURFACE AND COUNTERSUNK FLUTE**  
Provides better precision during drilling as well as optimal extraction of residues  
**GEPOLIJST OPPERVLAK EN VERZONKEN SPAANGROEF**  
Biedt betere precisie tijdens het boren, evenals optimale verwijdering van boorresten  
**SURFACE POLIE ET GOUJURE FRAISÉE**  
Fournit une meilleure précision lors du forage ainsi qu'une extraction optimale des résidus

- 4 SPECIAL CUTTING ANGLE OF 120°**  
Allows faster penetration into the material  
**SPECIALE SNIJHOEK VAN 120°**  
Maakt snellere penetratie in het materiaal mogelijk  
**ANGLE DE COUPE SPÉCIAL À 120°**  
Permet une pénétration plus rapide dans la matière

- 5 HEAD WITH 2 CUTTING EDGES**  
**KOP MET 2 SNIJRANDE**  
**TÊTE À 2 TAILLANTS**

- 6 DIAMOND GRINDED CUTTING EDGES**  
Its sharpening allows it to cut into hard materials  
**DIAMANTGESLEPEN SNIJRANDE**  
Door het slijpen kan het in harde materialen snijden  
**ARÊTES DE COUPE MEULÉE AU DIAMANT**  
Son affûtage lui permet de couper dans des matériaux durs

- 7 CYLINDRICAL SHANK**  
**CILINDRISCHE SCHACHT**  
**EMMANCHEMENT CYLINDRIQUE**



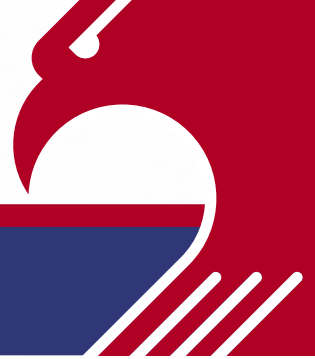

**GRANITEC drill for very hard materials**  
**GRANITEC boor voor zeer harde materialen**  
**GRANITEC foret pour les matériaux très durs**

code		Ø mm		
			L1 mm	L2 mm
SR 25801040	5420000051140	4,0	75	40
SR 25801050	5420000051157	5,0	85	50
SR 25801060	5420000051164	6,0	100	60
SR 25801080	5420000051171	8,0	120	75
SR 25801120	5420000051188	10,0	120	75

code		
<b>SET: Ø 4 - 5 - 6 - 8 - 10 mm (MULTIPACK)</b>		
SR 25801950	5420000051195	5 pcs / 5-delig / 5 pcs



## MULTITEC Gold Universal

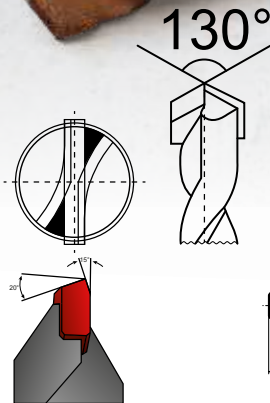
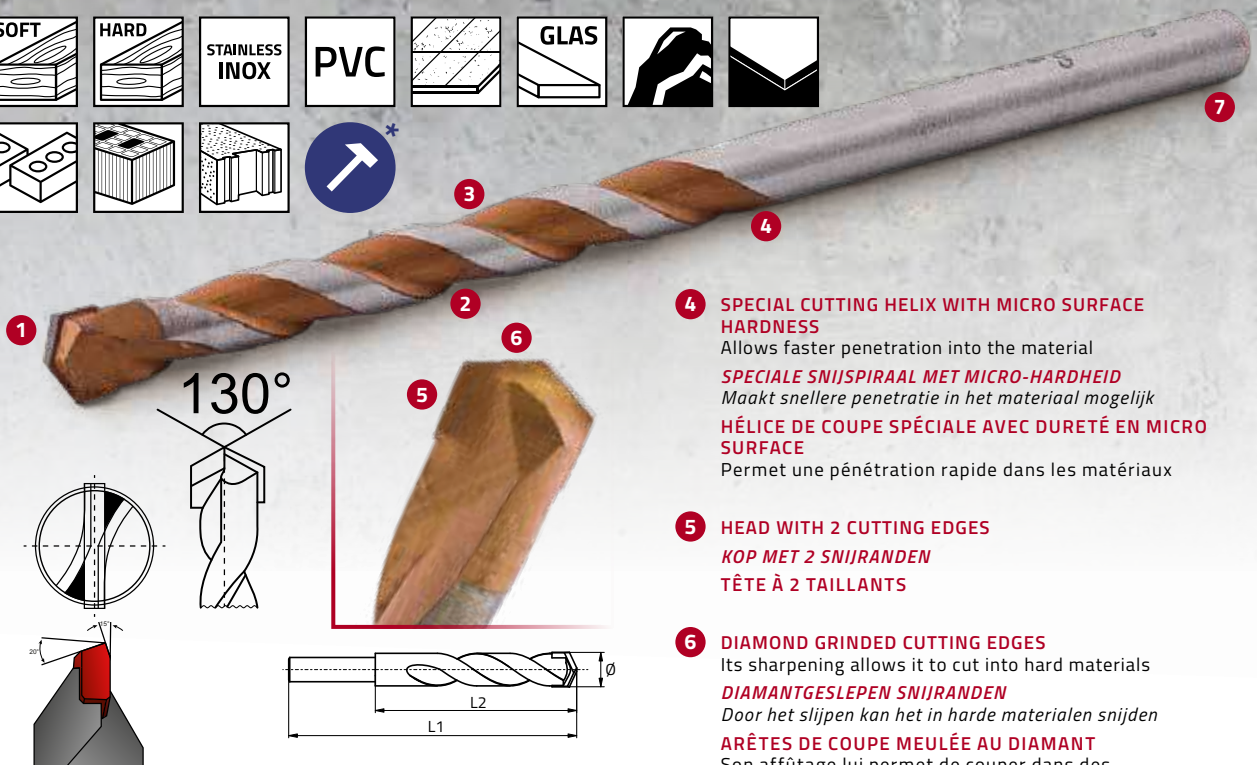
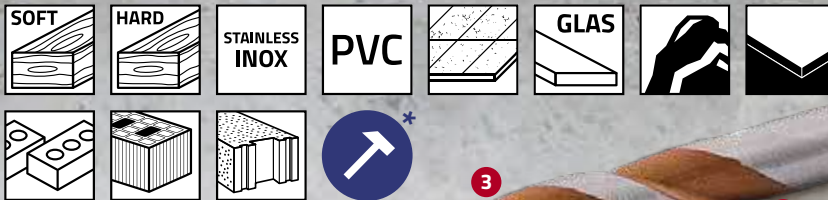

**1 TUNGSTEN CARBIDE TIP WITH SPECIAL CUTTING GEOMETRY**  
Allows drilling in almost all materials while offering extreme resistance to wear  
**WOLFRAMCARBIDE PUNT MET SPECIALE SNIJGEOMETRIE**  
Maakt boren in vrijwel alle materialen mogelijk en dit met extreme slijtvastheid  
**POINTE EN CARBURE DE TUNGSTÈNE AVEC GÉOMETRIE DE COUPE SPÉCIALE**  
Permet un forage dans presque tous les matériaux tout en offrant une résistance extrême à l'usure

**2 ASYMMETRICAL SPIRAL DESIGN WITH STRAIGHT FLUTE ENTRY**  
For a perfect extraction of drilling residues  
**ASYMMETRISCH SPIRAALONTWERP MET RECHTE SPAANGROEFINGANG**  
Voor een perfecte verwijdering van boorresten  
**CONCEPTION SPIRALÉE ASYMÉTRIQUE AVEC ENTRÉE DE GOJURE DROITE**  
Pour une extraction parfaite des résidus de forage

**3 POLISHED SURFACE AND COUNTERSUNK FLUTE**  
Provides better precision during drilling as well as optimal extraction of residues  
**GEPOLIJST OPPERVLAK EN VERZONKEN SPAANGROEF**  
Biedt betere precisie tijdens het boren, evenals optimale verwijdering van boorresten  
**SURFACE POLIE ET GOJURE FRAISÉE**  
Fournit une meilleure précision lors du forage ainsi qu'une extraction optimale des résidus

**4 SPECIAL CUTTING HELIX WITH MICRO SURFACE HARDNESS**  
Allows faster penetration into the material  
**SPECIALE SNIJSPIRAAL MET MICRO-HARDHEID**  
Maakt snellere penetratie in het materiaal mogelijk  
**HÉLICE DE COUPE SPÉCIALE AVEC DURETÉ EN MICRO SURFACE**  
Permet une pénétration rapide dans les matériaux

**5 HEAD WITH 2 CUTTING EDGES**  
**KOP MET 2 SNIJRANDE**  
**TÊTE À 2 TAILLANTS**

**6 DIAMOND GRINDED CUTTING EDGES**  
Its sharpening allows it to cut into hard materials  
**DIAMANTGESLEPEN SNIJRANDE**  
Door het slijpen kan het in harde materialen snijden  
**ARÊTES DE COUPE MEULÉE AU DIAMANT**  
Son affûtage lui permet de couper dans des matériaux durs

**7 CYLINDRICAL SHANK**  
**CILINDRISCHE SCHACHT**  
**EMMANCHEMENT CYLINDRIQUE**

code		Ø mm		
			L1 mm	L2 mm
SR 25750040	5420000051072	4,0	75	40
SR 25750050	5420000051089	5,0	85	50
SR 25750060	5420000051096	6,0	100	60
SR 25750080	5420000051102	8,0	120	80
SR 25750100	5420000051119	10,0	120	80
SR 25750120	5420000051126	12,0	150	90

code		
<b>SET : Ø 4 - 5 - 6 - 8 - 10 mm (MULTIPACK)</b>		
SR 25750255	5420000051133	5 pcs / 5-delig / 5 pcs

### TIPS

- Regrinding is necessary when the drill is used in abrasive materials and gives it a longer life
- Use only sharp drills when drilling in porcelain, ceramic and glass
- Herslijpen is noodzakelijk wanneer de boor wordt gebruikt in abrasieve materialen en geeft hierdoor een langere levensduur
- Gebruik alleen scherpe boren bij het boren in porselein, keramiek en glas
- Un réaffûtage est nécessaire lorsque le foret est utilisé dans des matériaux abrasifs et lui donne ainsi une durée de vie plus longue
- N'utiliser que des forets tranchants lors de forage dans la porcelaine, céramique et le verre

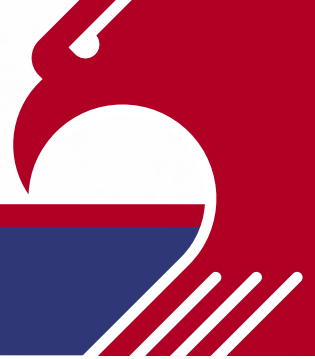

## MULTITEC Gold Universal

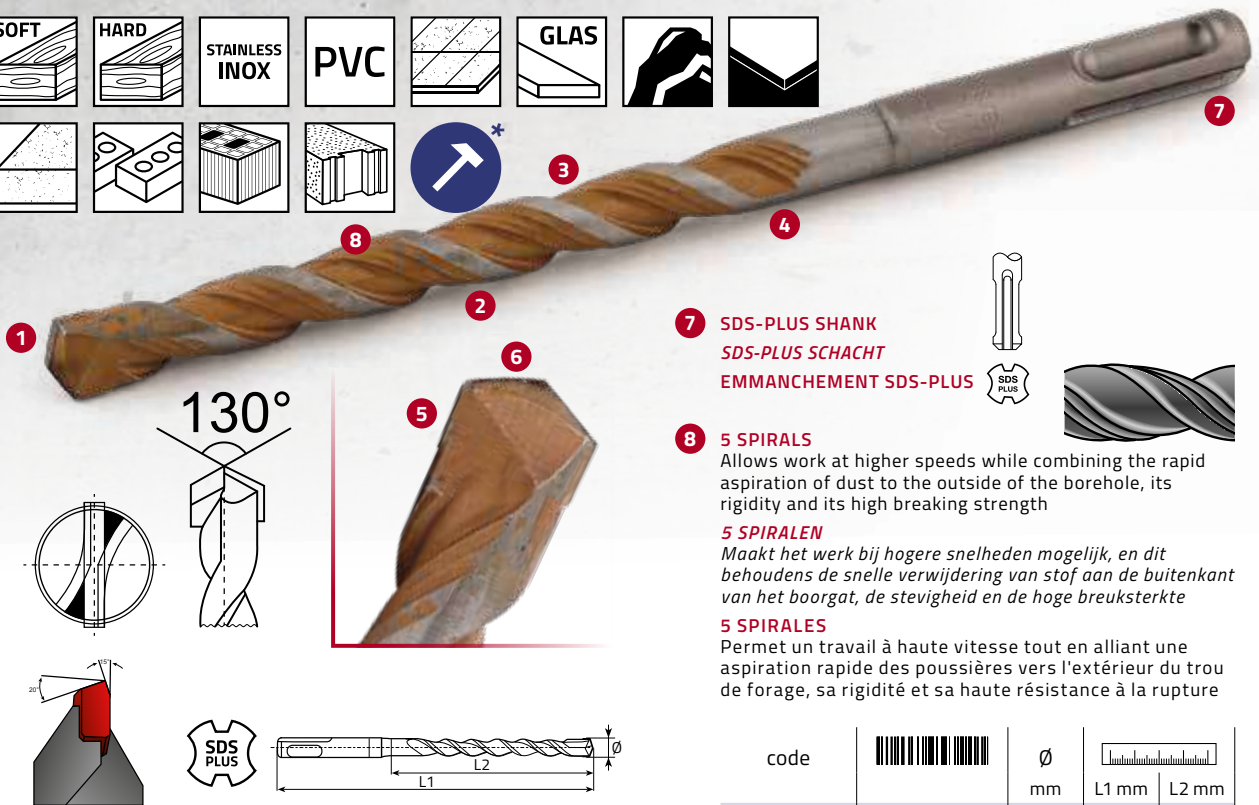
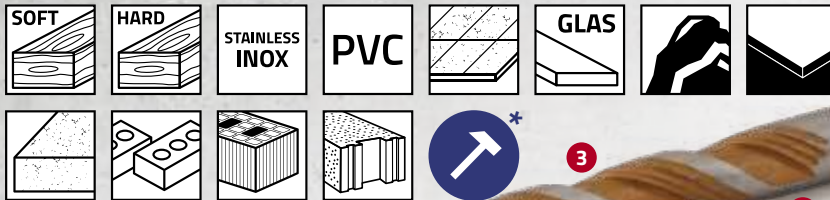

**7 SDS-PLUS SHANK**  
**SDS-PLUS SCHACHT**  
**EMMANCHEMENT SDS-PLUS**

**8 5 SPIRALS**  
 Allows work at higher speeds while combining the rapid aspiration of dust to the outside of the borehole, its rigidity and its high breaking strength  
**5 SPIRALEN**  
 Maakt het werk bij hogere snelheden mogelijk, en dit behoudens de snelle verwijdering van stof aan de buitenkant van het boorgat, de stevigheid en de hoge breuksterkte  
**5 SPIRALES**  
 Permet un travail à haute vitesse tout en alliant une aspiration rapide des poussières vers l'extérieur du trou de forage, sa rigidité et sa haute résistance à la rupture

code		Ø mm		
			L1 mm	L2 mm
SR 25690500	5420000051386	5,0	110	50
SR 25690610	5420000051393	6,0	160	100
SR 25690820	5420000051409	8,0	160	100
SR 25691010	5420000051416	10,0	160	100
SR 25691211	5420000051423	12,0	165	100

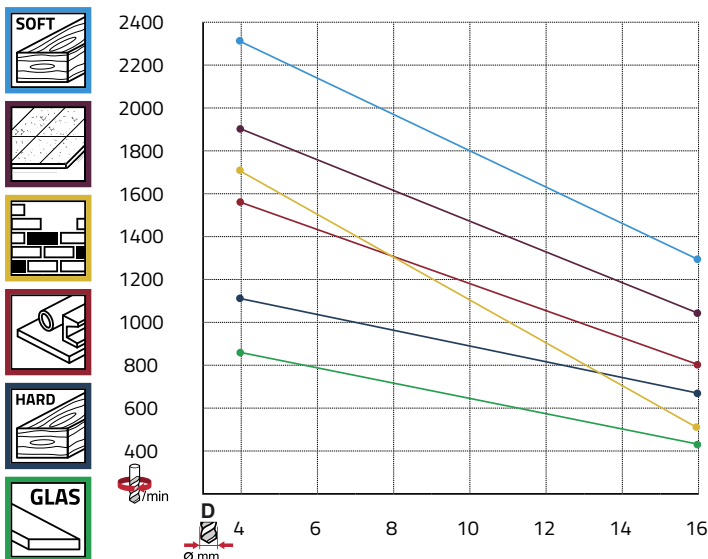

\* depending on the material  
 afhankelijk van het materiaal  
 en fonction du matériau



## SDS-Plus Turbo 2-cutter

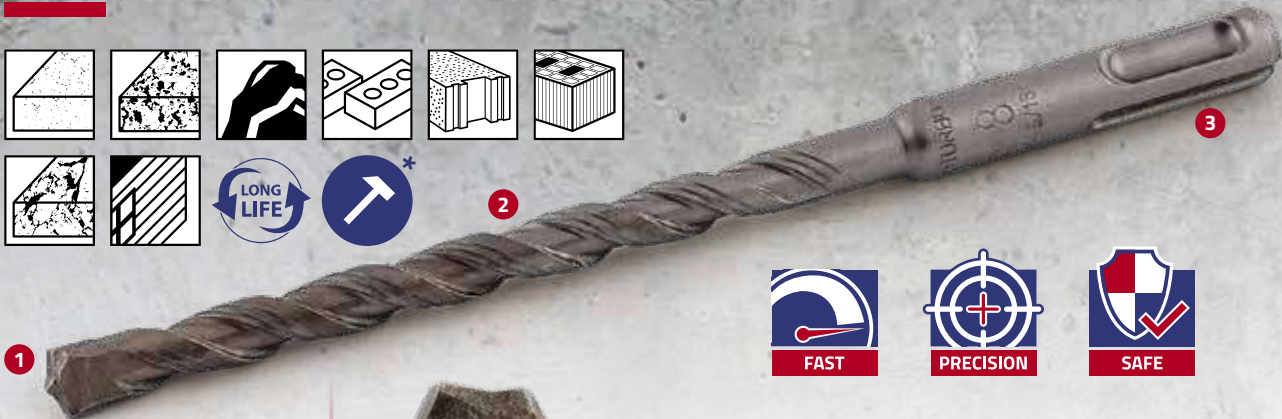
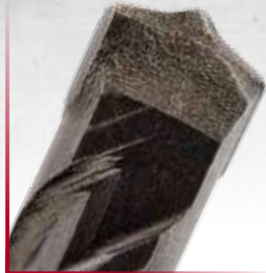
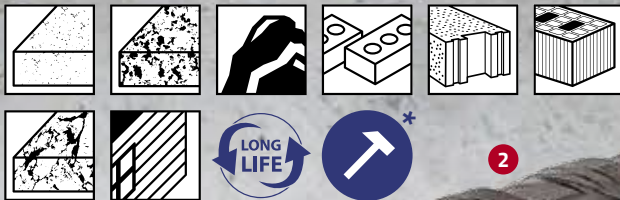

**1 STRENGTHENED CARBIDE TIP WITH CENTERING TIP**  
For precise drilling without slipping  
**VERSTERKT CARBIDEPUNT MET CENTREERPUNT**  
Voor nauwkeurig boren zonder te slippen  
**POINTE EN CARBURE RENFORCÉE AVEC POINTE DE CENTRAGE**  
Pour une perçage précis sans glisser

**2 SPIRAL FOR ERGONOMIC AND ECOLOGICAL WORK FLOW**  
- High drilling speed  
- Fast transport of drilling dust  
- High grade of stiffness and long service life  
- High resistance against breakage

**SPIRAAL VOOR EEN ERGONOMISCH EN ECOLOGISCH WERKRITME**

- Hoge snelheid van het boren
- Snel verplaatsen van stof dat vrijkomt bij het boren
- Hoge graad van hardheid en dus ook een lange levensduur
- Hoge weerstand tegen breken

**LES SPIRALES AMÉLIORENT L'ERGONOMIE DU TRAVAIL ET L'ÉCOLOGIE**

- Haute vitesse de forage
- Extraction rapide de la poussière qui se dégage pendant le forage
- Haute dureté = longue durée de vie
- Haute résistance à la rupture

**3 SDS-PLUS SHANK**  
**SDS-PLUS SCHACHT**  
**EMMANCHEMENT SDS-PLUS**



### TIPS

- For a working length of 400 mm and more, pre-drilling must be carried out to a depth of at least 150 mm with a drill bit of the same diameter.
- For a working length of 950 mm, pre-drilling must be carried out to a depth of at least 400 mm with a short drill bit of the same diameter.
- The warranty does not apply to extra-long drill bits of 1,000 mm and more.
- Voor een lengte van 400 mm of meer, moet er een lengte van 150 mm worden voorgeboord met een boor van dezelfde diameter.
- Voor een lengte van 950 mm, moet er een lengte van 400 mm worden voorgeboord met een korte boor van dezelfde diameter.
- Deze theorie is niet van toepassing voor extra lange boren van 1000 mm en meer.
- Pour une forage de plus de 400 mm, une longueur de 150 mm doit être forée au préalable avec un foret du même diamètre.
- Pour une forage de 950 mm, une longueur de 400 mm doit être forée au préalable avec un foret du même diamètre.
- Cette théorie n'est pas d'application pour les forets de 1000 mm et plus

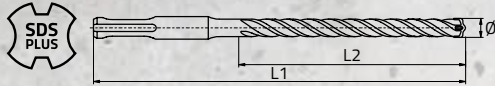
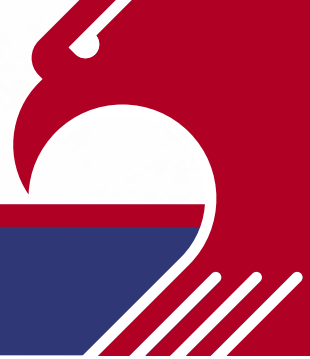

## SDS-Plus Turbo 2-cutter



code		Ø mm		
			L1 mm	L2 mm
SR 25040110	5420000050280	4,0	110	50
SR 25050110	5420000050303	5,0	110	50
SR 25060110	5420000050327	6,0	110	50
SR 25080110	5420000050389	8,0	110	50
SR 25040160	5420000050297	4,0	160	100
SR 25050160	5420000050310	5,0	160	100
SR 25060160	5420000050334	6,0	160	100
SR 25065160	5420000050365	6,5	160	100
SR 25080160	5420000050396	8,0	160	100
SR 25100160	5420000050433	10,0	160	100
SR 25120160	5420000050495	12,0	160	100
SR 25055210	5420000060555	5,5	210	150
SR 25060210	5420000050341	6,0	210	150
SR 25080210	5420000050402	8,0	210	150
SR 25100210	5420000050440	10,0	210	150
SR 25120210	5420000050501	12,0	210	150
SR 25140210	5420000050563	14,0	210	150
SR 25160210	5420000050631	16,0	210	150
SR 25060260	5420000050358	6,0	260	200
SR 25065260	5420000050372	6,5	260	200
SR 25080260	5420000050419	8,0	260	200
SR 25100260	5420000050457	10,0	260	200
SR 25120260	5420000050518	12,0	260	200
SR 25140260	5420000050570	14,0	260	200
SR 25150260	5420000050624	15,0	260	200
SR 25055310	5420000060562	5,5	310	250
SR 25120310	5420000050525	12,0	310	250
SR 25140310	5420000050587	14,0	310	250
SR 25160310	5420000050648	16,0	310	250
SR 25180300	5420000050686	18,0	300	250
SR 25200300	5420000050723	20,0	300	250
SR 25095360	5420000059009	9,5	360	300

code		Ø mm		
			L1 mm	L2 mm
SR 25080460	5420000050426	8,0	460	400
SR 25100460	5420000050464	10,0	460	400
SR 25120450	5420000050532	12,0	450	400
SR 25140450	5420000050594	14,0	450	400
SR 25160450	5420000050655	16,0	450	400
SR 25180450	5420000050693	18,0	450	400
SR 25200450	5420000050730	20,0	450	400
SR 25220450	5420000050761	22,0	450	400
SR 25240450	5420000050792	24,0	450	400
SR 25260450	5420000050815	26,0	450	400
SR 25100600	5420000050471	10,0	600	550
SR 25120600	5420000050549	12,0	600	550
SR 25140600	5420000050600	14,0	600	550
SR 25160600	5420000050662	16,0	600	550
SR 25180600	5420000050709	18,0	600	550
SR 25200600	5420000050747	20,0	600	550
SR 25220600	5420000050778	22,0	600	550
SR 25101000	5420000050488	10,0	1000	950
SR 25121000	5420000050556	12,0	1000	950
SR 25141000	5420000050617	14,0	1000	950
SR 25161000	5420000050679	16,0	1000	950
SR 25181000	5420000050716	18,0	1000	950
SR 25201000	5420000050754	20,0	1000	950
SR 25221000	5420000050785	22,0	1000	950
SR 25251000	5420000050808	25,0	1000	950
per 10 pieces / per 10 stuks / par 10 pièces				
SR 25516160	5420000050839	6,0	160	100
SR 25518160	5420000050860	8,0	160	100
SR 25516210	5420000050846	6,0	210	150
SR 25518210	5420000050877	8,0	210	150
SR 25516260	5420000050853	6,0	260	200
SR 25518260	5420000050884	8,0	260	200
SR 25521001	5420000050891	10,0	260	200
SR 25521200	5420000050907	12,0	260	200

code		
SET : Ø 5 - 10 - 12 x 160 mm (1 pc/st)		
Ø 6 - 8 x 160 mm (2 pcs/st) (MULTIPACK)		
SR 25510000	5420000050822	7 pcs / 7-delig / 7 pcs

\* depending on the material  
afhankelijk van het materiaal  
en fonction du matériau

## SDS-Plus Premium 4-cutter

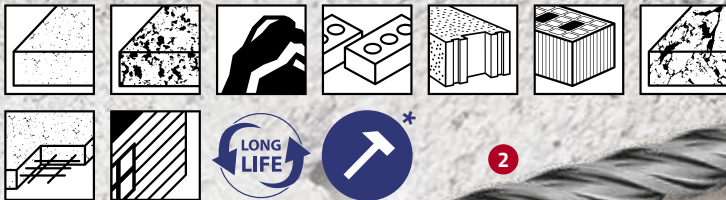

1

SDS PLUS  
**4CUTTER**



**1 CARBIDE TIPPED WITH 4 FLUTES AND CENTERING TIP**  
For precise drilling without slipping

**CARBIDEPUNT MET 4 SNIJVLAKKEN EN CENTREERPUNT**  
Voor nauwkeurig boren zonder te slippen

**POINTE EN CARBURE AVEC 4 TAILLANTS ET POINTE DE CENTRAGE**

Pour un perçage précis sans glisser

**2 SPIRAL FOR ERGONOMIC AND ECOLOGICAL WORK FLOW**

- High drilling speed
- Fast transport of drilling dust
- High grade of stiffness and long service life
- High resistance against breakage

**SPIRAAL VOOR EEN ERGONOMISCH EN ECOLOGISCH WERKRITME**

- Hoge snelheid van het boren
- Snel verplaatsen van stof dat vrijkomt bij het boren
- Hoge graad van hardheid en dus ook een lange levensduur
- Hoge weerstand tegen breken

**LES SPIRALES AMÉLIORENT L'ERGONOMIE DU TRAVAIL ET L'ÉCOLOGIE**

- Haute vitesse de forage
- Extraction rapide de la poussière qui se dégage pendant le forage
- Haute dureté = longue durée de vie
- Haute résistance à la rupture

**3 SDS-PLUS SHANK**  
**SDS-PLUS SCHACHT**  
**EMMANCHEMENT SDS-PLUS**



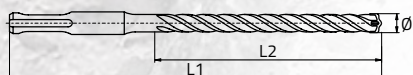
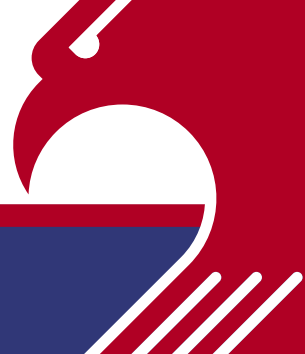

## SDS-Plus Premium 4-cutter



code	Barcode	Ø mm	Length	
			L1 mm	L2 mm
SR 24050111	5420000057180	5,0	110	50
SR 24060111	5420000057210	6,0	110	50
SR 24080111	5420000057302	8,0	110	50
SR 24050161	5420000057197	5,0	160	100
SR 24060161	5420000057227	6,0	160	100
SR 24065161	5420000057265	6,5	160	100
SR 24080161	5420000057319	8,0	160	100
SR 24100161	5420000057371	10,0	160	100
SR 24120161	5420000057456	12,0	160	110
SR 24140161	5420000057524	14,0	160	110
SR 24160161	5420000057609	16,0	160	110
SR 24060211	5420000057234	6,0	210	150
SR 24065211	5420000057272	6,5	210	150
SR 24080211	5420000057326	8,0	210	150
SR 24100211	5420000057388	10,0	210	150
SR 24120211	5420000057463	12,0	210	160
SR 24140211	5420000057531	14,0	210	160
SR 24160211	5420000057616	16,0	210	160
SR 24180251	5420000057678	18,0	250	200
SR 24200251	5420000057708	20,0	250	200
SR 24220251	5420000057739	22,0	250	200
SR 24240251	5420000057753	24,0	250	200
SR 24250251	5420000059924	25,0	250	200
SR 24300251	5420000057784	30,0	250	200
SR 24050261	5420000057203	5,0	260	200
SR 24060261	5420000057241	6,0	260	200
SR 24065261	5420000057289	6,5	260	200
SR 24080261	5420000057333	8,0	260	200
SR 24100261	5420000057395	10,0	260	200
SR 24120261	5420000057470	12,0	260	210
SR 24140261	5420000057548	14,0	260	210
SR 24150261	5420000057593	15,0	260	210
SR 24160261	5420000057623	16,0	260	210
SR 24060311	5420000057258	6,0	310	250
SR 24065311	5420000057296	6,5	310	250
SR 24080311	5420000057340	8,0	310	250
SR 24100311	5420000057401	10,0	310	250
SR 24120311	5420000057487	12,0	310	260
SR 24140311	5420000057555	14,0	310	260
SR 24160311	5420000057630	16,0	310	260

code	Barcode	Ø mm	Length	
			L1 mm	L2 mm
SR 24080361	5420000057357	8,0	360	300
SR 24100361	5420000057418	10,0	360	300
SR 24080461	5420000057364	8,0	460	400
SR 24100461	5420000057425	10,0	450	390
SR 24120461	5420000057494	12,0	450	400
SR 24140461	5420000057562	14,0	450	400
SR 24160461	5420000057647	16,0	450	400
SR 24180461	5420000057685	18,0	450	400
SR 24200461	5420000057715	20,0	450	400
SR 24220461	5420000057746	22,0	450	400
SR 24240461	5420000057760	24,0	450	400
SR 24250462	5420000059726	25,0	450	400
SR 24280461	5420000057777	28,0	450	400
SR 24300451	5420000057791	30,0	450	400
SR 24320451	5420000057807	32,0	450	400
SR 24100601	5420000057432	10,0	600	540
SR 24120601	5420000057500	12,0	600	550
SR 24140601	5420000057579	14,0	600	550
SR 24160601	5420000057654	16,0	600	550
SR 24100951	5420000057449	10,0	1000	940
SR 24120951	5420000057517	12,0	1000	950
SR 24140951	5420000057586	14,0	1000	950
SR 24160951	5420000057661	16,0	1000	950
SR 24180951	5420000057692	18,0	1000	950
SR 24200951	5420000057722	20,0	1000	950
per 10 pieces / per 10 stuks / par 10 pièces				
SR 24706160	5420000057814	6,0	160	100
SR 24708160	5420000057838	8,0	160	100
SR 24710160	5420000057852	10,0	160	100
SR 24706260	5420000057821	6,0	260	200
SR 24708260	5420000057845	8,0	260	200
SR 24710260	5420000057869	10,0	260	200
SR 24712260	5420000057876	12,0	260	210

code	Barcode	Info
SR 24750107	5420000062535	7 pcs / 7-delig / 7 pcs



7 pcs / 7-delig / 7 pcs

SR 24750107

## SDS-Max Premium 4-cutter

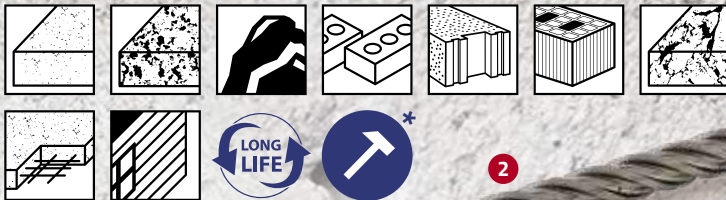

1



4CUTTER



2



1 CARBIDE TIPPED WITH 4 FLUTES AND CENTERING TIP  
For precise drilling without slipping

**CARBIDEPUNT MET 4 SNIJVLAKKEN EN CENTREERPUNT**  
Voor nauwkeurig boren zonder te slippen

**POINTE EN CARBURE AVEC 4 TAILLANTS ET POINTE DE CENTRAGE**

Pour un perçage précis sans glisser

2 SPIRAL FOR ERGONOMIC AND ECOLOGICAL WORK FLOW

- High drilling speed
- Fast transport of drilling dust
- High grade of stiffness and long service life
- High resistance against breakage

**SPIRAAL VOOR EEN ERGONOMISCH EN ECOLOGISCH WERKRITME**

- Hoge snelheid van het boren
- Snel verplaatsen van stof dat vrijkomt bij het boren
- Hoge graad van hardheid en dus ook een lange levensduur
- Hoge weerstand tegen breken

**LES SPIRALES AMÉLIORENT L'ERGONOMIE DU TRAVAIL ET L'ÉCOLOGIE**

- Haute vitesse de forage
- Extraction rapide de la poussière qui se dégage pendant le forage
- Haute dureté = longue durée de vie
- Haute résistance à la rupture

3 SDS-MAX SHANK  
SDS-MAX SCHACHT  
EMMANCHEMENT SDS-MAX



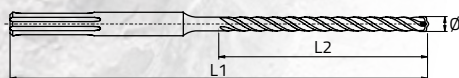
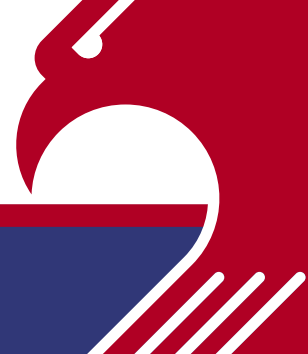

## SDS-Max Premium 4-cutter



code	Barcode	Ø mm	mm	
			L1 mm	L2 mm
SR 23120340	5420000057883	12,0	340	200
SR 23140340	5420000057906	14,0	340	200
SR 23150340	5420000057944	15,0	340	200
SR 23160340	5420000059917	16,0	340	200
SR 23200320	5420000057999	20,0	320	200
SR 23220320	5420000058026	22,0	320	200
SR 23240320	5420000058057	24,0	320	200
SR 23250320	5420000058071	25,0	320	200
SR 23280370	5420000058125	28,0	370	250
SR 23300370	5420000058170	30,0	370	250
SR 23320370	5420000058200	32,0	370	250
SR 23120540	5420000057890	12,0	540	400
SR 23140540	5420000057913	14,0	540	400
SR 23160540	5420000057951	16,0	540	400
SR 23180540	5420000057975	18,0	540	400
SR 23200520	5420000058002	20,0	520	400
SR 23220520	5420000058033	22,0	520	400
SR 23240520	5420000058064	24,0	520	400
SR 23250520	5420000058088	25,0	520	400
SR 23260520	5420000058118	26,0	520	400
SR 23280570	5420000058132	28,0	570	450
SR 23300570	5420000058187	30,0	570	450
SR 23320570	5420000058217	32,0	570	450
SR 23350570	5420000058248	35,0	570	450
SR 23380570	5420000058286	38,0	570	450
SR 23400570	5420000058293	40,0	570	450
SR 23450570	5420000058323	45,0	570	450
SR 23500570	5420000058330	50,0	570	450
SR 23520570	5420000058347	52,0	570	450

Designed for the heavier work !  
 Ontworpen voor het zwaardere werk !  
 Conçu pour les tâches les plus difficiles !

code	Barcode	Ø mm	mm	
			L1 mm	L2 mm
SR 23280670	5420000058149	28,0	670	550
SR 23350670	5420000058255	35,0	670	550
SR 23160940	5420000057968	16,0	940	800
SR 23180940	5420000057982	18,0	940	800
SR 23200920	5420000058019	20,0	920	800
SR 23220920	5420000058040	22,0	920	800
SR 23250920	5420000058095	25,0	920	800
SR 23280920	5420000058156	28,0	920	800
SR 23300920	5420000058194	30,0	920	800
SR 23320920	5420000058224	32,0	920	800
SR 23350920	5420000058262	35,0	920	800
SR 23400920	5420000058309	40,0	920	800
SR 23251320	5420000058101	25,0	1320	1200
SR 23281320	5420000058163	28,0	1320	1200
SR 23321320	5420000058231	32,0	1320	1200
SR 23351320	5420000058279	35,0	1320	1200
SR 23401320	5420000058316	40,0	1320	1200

## SDS-Max Connect System SDS-Max Connect System SDS-Max Connect System



SR 23880610



code	Barcode	mm
Extension / Verlengstuk / Extension		
SR 23880532	5420000062795	320
SR 23880575	5420000062801	750
Adapter, grease and instructions / Adapter, vet en instructies / Adaptateur, graisse et instructions		
SR 23880610	5420000063334	190



SR 23880532